

Bellows compensation device (BCD) SCU, type MP

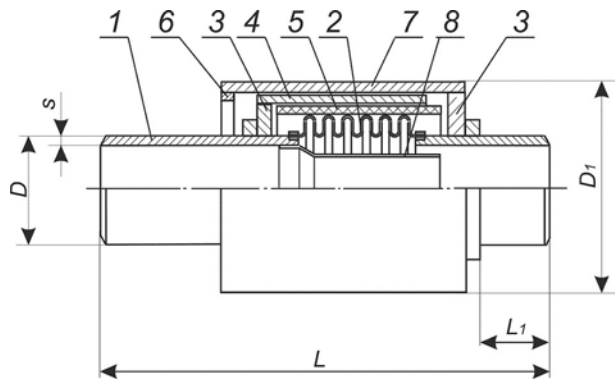

Single-bellows and double-bellows compensation devices consisting of one or two bellows and connection branch pipes further welded to a pipeline, with stroke limiters, a load-bearing casing and internal guide supports. The design provides for an internal guide pipe in order to reduce the hydraulic resistance at a high velocity of handled media. The bellows is thermally insulated. The bellows waterproofing and thermal insulation of branch pipes is not provided for. The outer surface of bellows and branch pipes has a corrosion-resistant waterproof coating.

Reference designation	PN, MPa	DN mm	Axial stroke, 2λ ₁ , mm	Dimensions, mm					Weight, kg
				D	D ₁	s	L	L ₁	
СКУ.МП-16-108x4,0-120-M01	1,6	100	120	108	219	4,0	847	200	39
СКУ.МП-16-133x5,0-130-M01		125	130	133	245	5,0	852		52
СКУ.МП-16-159x6,0-150-M01		150	150	159	299	6,0	865		77
СКУ.МП-16-219x6,0-160-M01		200	160	219	359	6,0	936		104
СКУ.МП-16-273x8,0-180-M01		250	180	273	409	8,0	973		147
СКУ.МП-16-325x8,0-190-M01		300	190	325	462	8,0	991		181
СКУ.МП-16-377x9,0-190-M01		350	190	377	512	9,0	1017*		224
СКУ.МП-16-426x9,0-200-M01		400	200	426	564	9,0	1049*		271
СКУ.МП-16-530x8,0-210-M02		500	210	530	700	8,0	1040*		359
СКУ.МП-16-630x8,0-220-M02		600	220	630	800	8,0	1066*		449
СКУ.МП-16-720x8,0-220-M02		700	220	720	910	8,0	1162		600
СКУ.МП-16-820x9,0-240-M02		800	240	820	1010	9,0	1142		686
СКУ.МП-16-920x10,0-260-M02		900	260	920	1156	10,0	1164		909
СКУ.МП-16-1020x12,0-260-M02		1000	260	1020	1256	12,0	1160		1040
СКУ.МП-16-1220x12,0-260-M02		1200	260	1220	1456	12,0	1160		1254
СКУ.МП-16-1420x12,0-260-M02		1400	260	1420	1656	12,0	1125		1433
СКУ.МП-25-108x4,0-120-M01	2,5	100	120	108	219	4,0	847	200	39
СКУ.МП-25-133x5,0-130-M01		125	130	133	245	5,0	852		52
СКУ.МП-25-159x6,0-150-M01		150	150	159	299	6,0	865		77
СКУ.МП-25-219x6,0-160-M01		200	160	219	359	6,0	936		104
СКУ.МП-25-273x8,0-180-M01		250	180	273	409	8,0	973		147
СКУ.МП-25-325x8,0-190-M01		300	190	325	462	8,0	991		181
СКУ.МП-25-377x9,0-190-M01		350	190	377	512	9,0	1017*		224
СКУ.МП-25-426x9,0-200-M01		400	200	426	564	9,0	1049*		271
СКУ.МП-25-530x8,0-210-M02		500	210	530	700	8,0	1040*		359
СКУ.МП-25-630x8,0-220-M02		600	220	630	800	8,0	1066*		449
СКУ.МП-25-720x8,0-220-M02		700	220	720	910	8,0	1162		600
СКУ.МП-25-820x9,0-240-M02		800	240	820	1010	9,0	1142		686
СКУ.МП-25-920x10,0-260-M02		900	260	920	1156	10,0	1164		909
СКУ.МП-25-1020x12,0-260-M02		1000	260	1020	1256	12,0	1160		1040
СКУ.МП-25-1220x12,0-260-M02		1200	260	1220	1456	12,0	1160		1254
СКУ.МП-25-1420x12,0-260-M02		1400	260	1420	1656	12,0	1125		1433

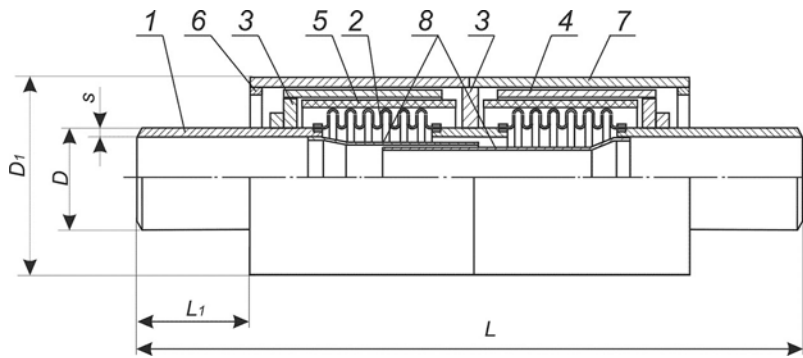

- 1 - патрубок присоединительный
- 2 - сиффон
- 3 - фланец опорный
- 4 - патрубок направляющий
- 5 - теплоизоляция
- 6 - ограничитель хода
- 7 - кожух
- 8 - патрубок внутренний направляющий

Reference designation	PN, MPa	DN mm	Axial stroke, $2\lambda_1$, mm	Dimensions, mm					Weight, kg
				D	D ₁	s	L	L ₁	
2СКУ.МП-16-219x6,0-320-M01	1,6	200	320	219	359	6,0	1442	200	178
2СКУ.МП-16-273x8,0-360-M01		250	360	273	409	8,0	1516		254
2СКУ.МП-16-325x8,0-380-M01		300	380	325	462	8,0	1552		314
2СКУ.МП-16-377x9,0-380-M01		350	380	377	512	9,0	1604*		389
2СКУ.МП-16-426x9,0-400-M01		400	400	426	564	9,0	1668*		477
2СКУ.МП-16-530x8,0-420-M02		500	420	530	700	8,0	1650*		628
2СКУ.МП-16-630x8,0-440-M02		600	440	630	800	8,0	1702*		783
2СКУ.МП-16-720x8,0-440-M02		700	440	720	910	8,0	1894		1064
2СКУ.МП-16-820x9,0-480-M02		800	480	820	1010	9,0	1854		1212
2СКУ.МП-16-920x10,0-520-M02		900	520	920	1156	10,0	1898		1611
2СКУ.МП-16-1020x12,0-520-M02		1000	520	1020	1256	12,0	1890		1825
2СКУ.МП-16-1220x12,0-520-M02		1200	520	1220	1456	12,0	1890		2209
2СКУ.МП-16-1420x12,0-520-M02		1400	520	1420	1656	12,0	1820		2518
2СКУ.МП-25-219x6,0-320-M01		2,5	200	320	219	359	6,0		1442
2СКУ.МП-25-273x8,0-360-M01	250		360	273	409	8,0	1516	254	
2СКУ.МП-25-325x8,0-380-M01	300		380	325	462	8,0	1552	314	
2СКУ.МП-25-377x9,0-380-M01	350		380	377	512	9,0	1604*	389	
2СКУ.МП-25-426x9,0-400-M01	400		400	426	564	9,0	1668*	477	
2СКУ.МП-25-530x8,0-420-M02	500		420	530	700	8,0	1650*	628	
2СКУ.МП-25-630x8,0-440-M02	600		440	630	800	8,0	1702*	783	
2СКУ.МП-25-720x8,0-440-M02	700		440	720	910	8,0	1894	1064	
2СКУ.МП-25-820x9,0-480-M02	800		480	820	1010	9,0	1854	1212	
2СКУ.МП-25-920x10,0-520-M02	900		520	920	1156	10,0	1898	1611	
2СКУ.МП-25-1020x12,0-520-M02	1000		520	1020	1256	12,0	1890	1825	
2СКУ.МП-25-1220x12,0-520-M02	1200		520	1220	1456	12,0	1890	2209	
2СКУ.МП-25-1420x12,0-520-M02	1400		520	1420	1656	12,0	1820	2518	