

Bellows compensation device (BCD) SCU, type PPU/PE.II

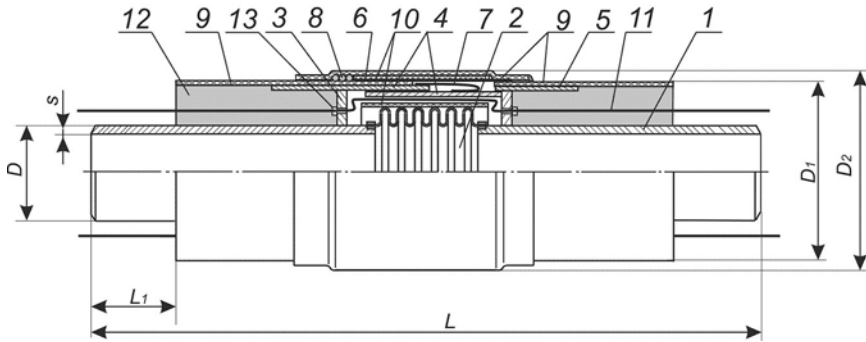

Single-bellows and double-bellows compensation devices consisting of one or two bellows and connection branch pipes further welded to a pipeline, with internal guides, compression stroke limiters, and the rapid remote control system conductors. The bellows is thermally insulated. The inner surface of a bellows compensation device is protected against ground waters by means of a waterproof membrane and gland packing. The outer surface of bellows and branch pipes has a corrosion-resistant waterproof coating.

Heat shrink couplings are installed above the bellows compensation device branch pipes for the connection to the PE sheath of a preinsulated pipeline in the course of installation. A larger heat-shrink coupling serving as a casing is extruded-bead welded to one of the couplings; it can move (with a minimum gap) along the second coupling of the bellows compensation device branch pipe in case of deformations thereof. The bellows compensation device branch pipes are PU-foam insulated.

Reference designation	PN, MPa	D Nmm	Axial stroke, 2λ ₁ , mm	Dimensions, mm						Weight, kg
				D	D ₁	D ₂	s	L	L ₁	
СКУ.ППУ/ПЭ.II-16-57x4,0/125-40-ОДК-М01	1,6	50	40	57	131	152	4,0	1385	150	15
СКУ.ППУ/ПЭ.II-16-57x4,0/140-40-ОДК-М03		50	40	57	147	172	4,0	1385		16
СКУ.ППУ/ПЭ.II-16-76x4,0/140-80-ОДК-М01		65	80	76	147	168	4,0	1385		18
СКУ.ППУ/ПЭ.II-16-76x4,0/160-80-ОДК-М03		65	80	76	167	192	4,0	1385		19
СКУ.ППУ/ПЭ.II-16-89x4,0/160-90-ОДК-М01		80	90	89	167	188	4,0	1405		21
СКУ.ППУ/ПЭ.II-16-89x4,0/180-90-ОДК-М03		80	90	89	187	213	4,0	1405		22
СКУ.ППУ/ПЭ.II-16-108x4,0/180-120-ОДК-М01		100	120	108	187	209	4,0	1465		29
СКУ.ППУ/ПЭ.II-16-108x4,0/200-120-ОДК-М03		100	120	108	208	239	4,0	1465		31
СКУ.ППУ/ПЭ.II-16-133x5,0/225-130-ОДК-М01		125	130	133	233	256	5,0	1385		40
СКУ.ППУ/ПЭ.II-16-133x5,0/250-130-ОДК-М03		125	130	133	259	290	5,0	1385		43
СКУ.ППУ/ПЭ.II-16-159x6,0/250-150-ОДК-М01		150	150	159	259	282	6,0	1425		54
СКУ.ППУ/ПЭ.II-16-159x6,0/280-150-ОДК-М03		150	150	159	285	310	6,0	1425		56
СКУ.ППУ/ПЭ.II-16-219x8,0/315-160-ОДК-М01		200	160	219	326	351	8,0	1445	88	
СКУ.ППУ/ПЭ.II-16-219x8,0/355-160-ОДК-М03		200	160	219	363	391	8,0	1445	92	
СКУ.ППУ/ПЭ.II-16-273x8,0/400-180-ОДК-М01		250	180	273	413	442	8,0	1630	154	
СКУ.ППУ/ПЭ.II-16-273x8,0/450-180-ОДК-М03		250	180	273	453	482	8,0	1630	164	
СКУ.ППУ/ПЭ.II-16-325x8,0/450-190-ОДК-М01		300	190	325	463	492	8,0	1650	186	
СКУ.ППУ/ПЭ.II-16-325x8,0/500-190-ОДК-М03		300	190	325	510	541	8,0	1650	198	
СКУ.ППУ/ПЭ.II-16-377x9,0/500-190-ОДК-М01		350	190	377	510	541	9,0	1605	231	
СКУ.ППУ/ПЭ.II-16-377x9,0/560-190-ОДК-М03		350	190	377	567	600	9,0	1605	247	
СКУ.ППУ/ПЭ.II-16-426x9,0/560-200-ОДК-М01		400	200	426	567	600	9,0	1630	278	
СКУ.ППУ/ПЭ.II-16-426x9,0/600-200-ОДК-М03		400	200	426	608	642	9,0	1630	290	
СКУ.ППУ/ПЭ.II-16-426x9,0/630-200-ОДК-М03		400	200	426	639	674	9,0	1630	300	
СКУ.ППУ/ПЭ.II-16-530x8,0/710-210-ОДК-М02		500	210	530	716	755	8,0	1675	427	
СКУ.ППУ/ПЭ.II-16-630x8,0/800-220-ОДК-М02		600	220	630	814	856	8,0	1700	528	
СКУ.ППУ/ПЭ.II-16-720x8,0/900-220-ОДК-М02		700	220	720	912	957	8,0	1695	633	
СКУ.ППУ/ПЭ.II-16-820x9,0/1000-240-ОДК-М02		800	240	820	1015	1063	9,0	1750	776	
СКУ.ППУ/ПЭ.II-16-820x9,0/1100-240-ОДК-М02		800	240	820	1119	1166	9,0	1750	803	
СКУ.ППУ/ПЭ.II-16-920x10,0/1100-260-ОДК-М02		900	260	920	1119	1166	10,0	1820	937	
СКУ.ППУ/ПЭ.II-16-920x10,0/1200-260-ОДК-М02		900	260	920	1219	1266	10,0	1820	959	
СКУ.ППУ/ПЭ.II-16-1020x12,0/1200-260-ОДК-М02		1000	260	1020	1224	1271	12,0	1820	1123	
СКУ.ППУ/ПЭ.II-16-1220x12,0/1425-260-ОДК-М02		1200	260	1220	1445	1493	12,0	1820	1351	

Reference designation	PN, MPa	D mm	Axial stroke, 2λ ₁ , mm	Dimensions, mm						Weight, kg
				D	D ₁	D ₂	s	L	L ₁	
СКУ.ППУ/ПЭ.ИИ-25-57x4,0/125-40-ОДК-М01	2,5	50	40	57	131	152	4,0	1385	150	15
СКУ.ППУ/ПЭ.ИИ-25-57x4,0/140-40-ОДК-М03		50	40	57	147	172	4,0	1385		16
СКУ.ППУ/ПЭ.ИИ-25-76x4,0/140-80-ОДК-М01		65	80	76	147	168	4,0	1385		18
СКУ.ППУ/ПЭ.ИИ-25-76x4,0/160-80-ОДК-М03		65	80	76	167	192	4,0	1385		19
СКУ.ППУ/ПЭ.ИИ-25-89x4,0/160-90-ОДК-М01		80	90	89	167	188	4,0	1405		21
СКУ.ППУ/ПЭ.ИИ-25-89x4,0/180-90-ОДК-М03		80	90	89	187	213	4,0	1405		22
СКУ.ППУ/ПЭ.ИИ-25-108x4,0/180-120-ОДК-М01		100	120	108	187	209	4,0	1465		29
СКУ.ППУ/ПЭ.ИИ-25-108x4,0/200-120-ОДК-М03		100	120	108	208	239	4,0	1465		31
СКУ.ППУ/ПЭ.ИИ-25-133x5,0/225-130-ОДК-М01		125	130	133	233	256	5,0	1385		40
СКУ.ППУ/ПЭ.ИИ-25-133x5,0/250-130-ОДК-М03		125	130	133	259	290	5,0	1385		43
СКУ.ППУ/ПЭ.ИИ-25-159x6,0/250-150-ОДК-М01		150	150	159	259	282	6,0	1425		54
СКУ.ППУ/ПЭ.ИИ-25-159x6,0/280-150-ОДК-М03		150	150	159	285	310	6,0	1425		56
СКУ.ППУ/ПЭ.ИИ-25-219x8,0/315-160-ОДК-М01		200	160	219	326	351	8,0	1445		88
СКУ.ППУ/ПЭ.ИИ-25-219x8,0/355-160-ОДК-М03		200	160	219	363	391	8,0	1445		92
СКУ.ППУ/ПЭ.ИИ-25-273x8,0/400-180-ОДК-М01		250	180	273	413	442	8,0	1630		154
СКУ.ППУ/ПЭ.ИИ-25-273x8,0/450-180-ОДК-М03		250	180	273	453	482	8,0	1630	164	
СКУ.ППУ/ПЭ.ИИ-25-325x8,0/450-190-ОДК-М01		300	190	325	463	492	8,0	1650	186	
СКУ.ППУ/ПЭ.ИИ-25-325x8,0/500-190-ОДК-М03		300	190	325	510	541	8,0	1650	198	
СКУ.ППУ/ПЭ.ИИ-25-377x9,0/500-190-ОДК-М01		350	190	377	510	541	9,0	1605	231	
СКУ.ППУ/ПЭ.ИИ-25-377x9,0/560-190-ОДК-М03		350	190	377	567	600	9,0	1605	247	
СКУ.ППУ/ПЭ.ИИ-25-426x9,0/560-200-ОДК-М01		400	200	426	567	600	9,0	1630	278	
СКУ.ППУ/ПЭ.ИИ-25-426x9,0/600-200-ОДК-М03		400	200	426	608	642	9,0	1630	290	
СКУ.ППУ/ПЭ.ИИ-25-426x9,0/630-200-ОДК-М03		400	200	426	639	674	9,0	1630	300	
СКУ.ППУ/ПЭ.ИИ-25-530x8,0/710-210-ОДК-М02		500	210	530	716	755	8,0	1675	427	
СКУ.ППУ/ПЭ.ИИ-25-630x8,0/800-220-ОДК-М02		600	220	630	814	856	8,0	1700	528	
СКУ.ППУ/ПЭ.ИИ-25-720x8,0/900-220-ОДК-М02		700	220	720	912	957	8,0	1695	633	
СКУ.ППУ/ПЭ.ИИ-25-820x9,0/1000-240-ОДК-М02		800	240	820	1015	1063	9,0	1750	776	
СКУ.ППУ/ПЭ.ИИ-25-820x9,0/1100-240-ОДК-М02		800	240	820	1119	1166	9,0	1750	803	
СКУ.ППУ/ПЭ.ИИ-25-920x10,0/1100-260-ОДК-М02		900	260	920	1119	1166	10,0	1820	937	
СКУ.ППУ/ПЭ.ИИ-25-920x10,0/1200-260-ОДК-М02		900	260	920	1219	1266	10,0	1820	959	
СКУ.ППУ/ПЭ.ИИ-25-1020x12,0/1200-260-ОДК-М02	1000	260	1020	1224	1271	12,0	1820	1123		
СКУ.ППУ/ПЭ.ИИ-25-1220x12,0/1425-260-ОДК-М02	1200	260	1220	1445	1493	12,0	1820	1351		

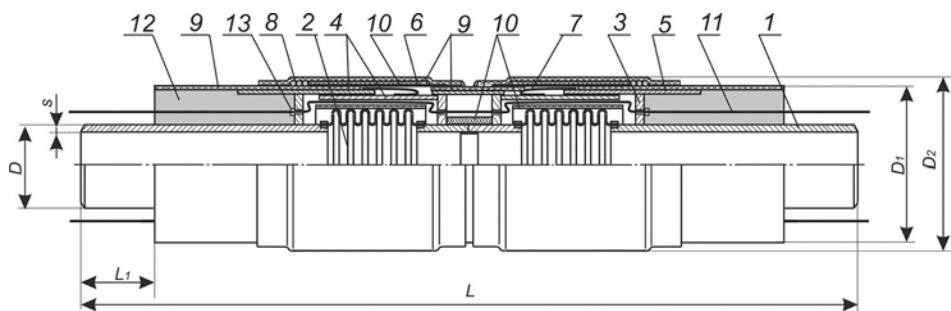

Reference designation	PN, MP	D Nmm	Axial stroke, 2λ ₁ , mm	Dimensions, mm						Weight, kg
				D	D ₁	D ₂	s	L	L ₁	
2СКУ.ППУ/ПЭ.II-16-57x4,0/125-80-ОДК-М01	a	50	80	57	131	152	4,0	1830	150	23
2СКУ.ППУ/ПЭ.II-16-57x4,0/140-80-ОДК-М03		50	80	57	147	172	4,0	1830		23
2СКУ.ППУ/ПЭ.II-16-76x4,0/140-160-ОДК-М01		65	160	76	147	168	4,0	1830		27
2СКУ.ППУ/ПЭ.II-16-76x4,0/160-160-ОДК-М03		65	160	76	167	192	4,0	1830		29
2СКУ.ППУ/ПЭ.II-16-89x4,0/160-180-ОДК-М01		80	180	89	167	188	4,0	1870		35
2СКУ.ППУ/ПЭ.II-16-89x4,0/180-180-ОДК-М03		80	180	89	187	213	4,0	1870		37
2СКУ.ППУ/ПЭ.II-16-108x4,0/180-240-ОДК-М01		100	240	108	187	209	4,0	1990		47
2СКУ.ППУ/ПЭ.II-16-108x4,0/200-240-ОДК-М03		100	240	108	208	239	4,0	1990		49
2СКУ.ППУ/ПЭ.II-16-133x5,0/225-260-ОДК-М01		125	260	133	233	256	5,0	1930		64
2СКУ.ППУ/ПЭ.II-16-133x5,0/250-260-ОДК-М03		125	260	133	259	290	5,0	1930		67
2СКУ.ППУ/ПЭ.II-16-159x6,0/250-300-ОДК-М01		150	300	159	259	282	6,0	2010		85
2СКУ.ППУ/ПЭ.II-16-159x6,0/280-300-ОДК-М03		150	300	159	285	310	6,0	2010		88
2СКУ.ППУ/ПЭ.II-16-219x8,0/315-320-ОДК-М01		200	320	219	326	351	8,0	2050		136
2СКУ.ППУ/ПЭ.II-16-219x8,0/355-320-ОДК-М03		200	320	219	363	391	8,0	2050		140
2СКУ.ППУ/ПЭ.II-16-273x8,0/400-360-ОДК-М01		250	360	273	413	442	8,0	2320		249
2СКУ.ППУ/ПЭ.II-16-273x8,0/450-360-ОДК-М03		250	360	273	453	482	8,0	2320	261	
2СКУ.ППУ/ПЭ.II-16-325x8,0/450-380-ОДК-М01		300	380	325	463	492	8,0	2360	301	
2СКУ.ППУ/ПЭ.II-16-325x8,0/500-380-ОДК-М03		300	380	325	510	541	8,0	2360	316	
2СКУ.ППУ/ПЭ.II-16-377x9,0/500-380-ОДК-М01		350	380	377	510	541	9,0	2330	375	
2СКУ.ППУ/ПЭ.II-16-377x9,0/560-380-ОДК-М03		350	380	377	567	600	9,0	2330	394	
2СКУ.ППУ/ПЭ.II-16-426x9,0/560-400-ОДК-М01		400	400	426	567	600	9,0	2380	458	
2СКУ.ППУ/ПЭ.II-16-426x9,0/600-400-ОДК-М03		400	400	426	608	642	9,0	2380	474	
2СКУ.ППУ/ПЭ.II-16-426x9,0/630-400-ОДК-М03		400	400	426	639	674	9,0	2380	487	
2СКУ.ППУ/ПЭ.II-16-530x8,0/710-420-ОДК-М02		500	420	530	716	755	8,0	2522	745	
2СКУ.ППУ/ПЭ.II-16-630x8,0/800-440-ОДК-М02		600	440	630	814	856	8,0	2572	925	
2СКУ.ППУ/ПЭ.II-16-720x8,0/900-440-ОДК-М02		700	440	720	912	957	8,0	2572	1121	
2СКУ.ППУ/ПЭ.II-16-820x9,0/1000-480-ОДК-М02		800	480	820	1015	1063	9,0	2672	1368	
2СКУ.ППУ/ПЭ.II-16-820x9,0/1100-480-ОДК-М02		800	480	820	1119	1166	9,0	2672	1461	
2СКУ.ППУ/ПЭ.II-16-920x10,0/1100-520-ОДК-М02		900	520	920	1119	1166	10,0	2812	1643	
2СКУ.ППУ/ПЭ.II-16-920x10,0/1200-520-ОДК-М02		900	520	920	1219	1266	10,0	2812	1739	
2СКУ.ППУ/ПЭ.II-16-1020x12,0/1200-520-ОДК-М02		1000	520	1020	1224	1271	12,0	2812	1941	
2СКУ.ППУ/ПЭ.II-16-1220x12,0/1425-520-ОДК-М02		1200	520	1220	1445	1493	12,0	2812	2338	

Reference designation	PN, MPa	DN, mm	Axial stroke, 2λ ₁ , mm	Dimensions, mm						Weight, kg
				D	D ₁	D ₂	s	L	L ₁	
2СКУ.ППУ/ПЭ.ИИ-25-57x4,0/125-80-ОДК-М01	2,5	50	80	57	131	152	4,0	1830	150	23
2СКУ.ППУ/ПЭ.ИИ-25-57x4,0/140-80-ОДК-М03		50	80	57	147	172	4,0	1830		23
2СКУ.ППУ/ПЭ.ИИ-25-76x4,0/140-160-ОДК-М01		65	160	76	147	168	4,0	1830		27
2СКУ.ППУ/ПЭ.ИИ-25-76x4,0/160-160-ОДК-М03		65	160	76	167	192	4,0	1830		29
2СКУ.ППУ/ПЭ.ИИ-25-89x4,0/160-180-ОДК-М01		80	180	89	167	188	4,0	1870		35
2СКУ.ППУ/ПЭ.ИИ-25-89x4,0/180-180-ОДК-М03		80	180	89	187	213	4,0	1870		37
2СКУ.ППУ/ПЭ.ИИ-25-108x4,0/180-240-ОДК-М01		100	240	108	187	209	4,0	1990		47
2СКУ.ППУ/ПЭ.ИИ-25-108x4,0/200-240-ОДК-М03		100	240	108	208	239	4,0	1990		49
2СКУ.ППУ/ПЭ.ИИ-25-133x5,0/225-260-ОДК-М01		125	260	133	233	256	5,0	1930		64
2СКУ.ППУ/ПЭ.ИИ-25-133x5,0/250-260-ОДК-М03		125	260	133	259	290	5,0	1930		67
2СКУ.ППУ/ПЭ.ИИ-25-159x6,0/250-300-ОДК-М01		150	300	159	259	282	6,0	2010	85	
2СКУ.ППУ/ПЭ.ИИ-25-159x6,0/280-300-ОДК-М03		150	300	159	285	310	6,0	2010	88	
2СКУ.ППУ/ПЭ.ИИ-25-219x8,0/315-320-ОДК-М01		200	320	219	326	351	8,0	2050	136	
2СКУ.ППУ/ПЭ.ИИ-25-219x8,0/355-320-ОДК-М03		200	320	219	363	391	8,0	2050	140	
2СКУ.ППУ/ПЭ.ИИ-25-273x8,0/400-360-ОДК-М01		250	360	273	413	442	8,0	2320	249	
2СКУ.ППУ/ПЭ.ИИ-25-273x8,0/450-360-ОДК-М03		250	360	273	453	482	8,0	2320	261	
2СКУ.ППУ/ПЭ.ИИ-25-325x8,0/450-380-ОДК-М01		300	380	325	463	492	8,0	2360	301	
2СКУ.ППУ/ПЭ.ИИ-25-325x8,0/500-380-ОДК-М03		300	380	325	510	541	8,0	2360	316	
2СКУ.ППУ/ПЭ.ИИ-25-377x9,0/500-380-ОДК-М01		350	380	377	510	541	9,0	2330	375	
2СКУ.ППУ/ПЭ.ИИ-25-377x9,0/560-380-ОДК-М03		350	380	377	567	600	9,0	2330	394	
2СКУ.ППУ/ПЭ.ИИ-25-426x9,0/560-400-ОДК-М01	400	400	426	567	600	9,0	2380	458		
2СКУ.ППУ/ПЭ.ИИ-25-426x9,0/600-400-ОДК-М03	400	400	426	608	642	9,0	2380	474		
2СКУ.ППУ/ПЭ.ИИ-25-426x9,0/630-400-ОДК-М03	400	400	426	639	674	9,0	2380	487		
2СКУ.ППУ/ПЭ.ИИ-25-530x8,0/710-420-ОДК-М02	500	420	530	716	755	8,0	2522	745		
2СКУ.ППУ/ПЭ.ИИ-25-630x8,0/800-440-ОДК-М02	600	440	630	814	856	8,0	2572	925		
2СКУ.ППУ/ПЭ.ИИ-25-720x8,0/900-440-ОДК-М02	700	440	720	912	957	8,0	2572	1121		
2СКУ.ППУ/ПЭ.ИИ-25-820x9,0/1000-480-ОДК-М02	800	480	820	1015	1063	9,0	2672	1368		
2СКУ.ППУ/ПЭ.ИИ-25-820x9,0/1100-480-ОДК-М02	800	480	820	1119	1166	9,0	2672	1461		
2СКУ.ППУ/ПЭ.ИИ-25-920x10,0/1100-520-ОДК-М02	900	520	920	1119	1166	10,0	2812	1643		
2СКУ.ППУ/ПЭ.ИИ-25-920x10,0/1200-520-ОДК-М02	900	520	920	1219	1266	10,0	2812	1739		
2СКУ.ППУ/ПЭ.ИИ-25-1020x12,0/1200-520-ОДК-М02	1000	520	1020	1224	1271	12,0	2812	1941		
2СКУ.ППУ/ПЭ.ИИ-25-1220x12,0/1425-520-ОДК-М02	1200	520	1220	1445	1493	12,0	2812	2338		